

Witness and Victim Protection Complex SRS Anonymity System

□ Purpose

SRS Anonymity System is a hardware and software complex, designed for witness and victim protection ensuring his/her identity concealment while stating evidence at criminal proceeding by means of voice modification without possibility to restore the original voice.

The application of **SRS Anonymity System** allows preventing multiple cases when victims and witnesses refuse or avoid stating evidence in criminal proceedings.

□ Application

SRS Anonymity System is used within the witness protection program, as it implies modification of witness's voice and ensures security of victims, witnesses and other participants of criminal proceeding.

During the court proceeding the witness is in a separate room – "secret room", which may be either in the court building or outside it.

The audio and video from the courtroom are broadcasted to the "secret room" and the witness's modified voice is broadcasted to the courtroom. If needed, video of the witness is broadcasted to the judge's personal monitor to identify the witness. The connection is established via LAN or Internet through the secure channel with application of special hardware. The audio and video are transmitted without significant delay and quality loss.

Currently the complexes of **SRS Anonymity System** have been successfully used in the courts of Azerbaijan, Bulgaria, Kenya, Moldova, Romania, Turkey, Spain, Ukraine and public prosecution office of Macedonia.

□ Advantages

SRS Anonymity System enables virtual presence of witness at criminal proceeding, and his/her anonymity by means of the voice modification at stating evidence.

The voice modification device "**SRS Femida Audio Interface VC12**" ensures non-restoration of the modified voice at sufficient speech intelligibility.

Modification of victim's or witness's voice enables their examination without declaring their identities.

□ Structure

SRS Anonymity System includes the voice modification system, microphone system, video system, public address system and video conferencing facilities or can use the corresponding equipment installed in the courtroom.

SRS Anonymity System is seamlessly integrated with the Court Recording System **SRS Femida**.

Components:

- Courtroom:
- Microphone system (microphones, preamplifier/mixer);
 - Public address system (amplifier, acoustic system);
 - Video system (monitor, video cameras);
 - Video conferencing terminal.

- Witness's room:
- Voice modification device "SRS Femida Audio Interface VC12";
 - Microphone;
 - Acoustic system and headset;
 - Video system (monitor, video camera (optionally));
 - Video conferencing terminal.

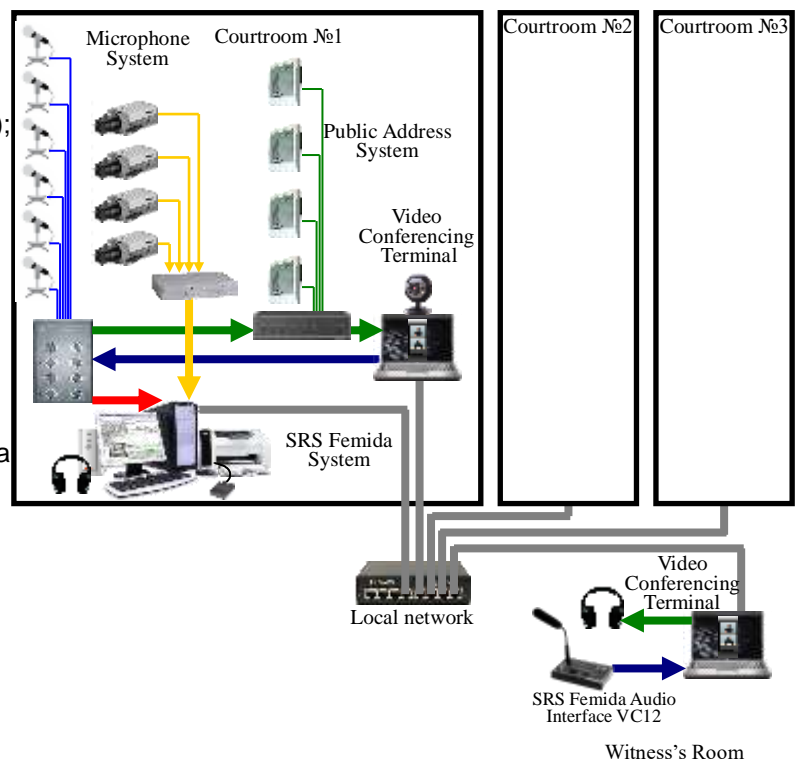

❑ Voice Modification Device “SRS Femida Audio Interface VC12”

The **SRS Femida Audio Interface VC12** voice modification device utilizes a unique algorithm of vocoder transformation of speech signal with modification of voice individual characteristics excluding the possibility of revealing a protected witness or victim by his/her voice. As a result of this transformation, the voice becomes unrecognizable, though its intelligibility is preserved and all modified voices sound practically with the same timbre.

SRS Femida Audio Interface VC12 allows concealment of speaker's original intonation and creation of monotonous intonation of the voice. The original speakers' voices characteristics are replaced by the preset ones.

The voice modification device **SRS Femida Audio Interface VC12** is implemented on the basis of the DSP signal processor and available in the desktop model.

❑ Main Functions



- Desktop all-in-one design
- Automatic voice modification modes (Low timbre/High timbre)
- Monotone mode on/off
- Analog line inputs/outputs
- Balanced microphone input with phantom power
- USB interface for connecting to a PC
- AGC and threshold noise reduction for inputs
- Built-in push-to-talk button
- Built-in speaker with volume control knob

❑ SRS Femida Audio Interface VC12 Technical Specification

Name	Description
Operation modes	<ul style="list-style-type: none">• Low voice with monotone effect• High voice with monotone effect
Inputs	<ul style="list-style-type: none">• Microphone with phantom power• Linear
Outputs	<ul style="list-style-type: none">• Linear• Headsets (adjustable)• Digital USB
Nominal level of input signal on microphone input	2,5 ÷ 25,0 mV (AGC, Limiter, and Noise Gate are used)
Nominal level of input signal on linear input	1000 mV
Nominal level of output signal on linear output	1000 mV
Frequency range of input signal	70 Hz ÷ 3600 Hz
Acceptable frequency range of main tone of input signal	70 Hz ÷ 400 Hz
Range of transformation of main tone frequency	± 1 octave
Range of speech formants transformation	± 1 octave
Voice delay inserted by the system	<50 ms
Nominal signal power at output for headsets	30 mW
Intrinsic noises level	-78 dBu
Type of connected microphone	Condenser, super-cardioid
Weight	2,5 kg (with a box)
Delivery kit	Audio interface “SRS Femida Audio Interface VC12”, SRS CM-14 condenser microphone, USB A-B cable, power supply 5V/4A



Special Recording Systems, Ltd.

Address: 5 Solomyanska str., office 218, Kyiv, 03110, Ukraine
Tel/Fax: 0 800 501-8640 (free in Ukraine)
+380 44 248-7990(91) (Ukraine, GMT+02:00)

E-mail: info@srs.kiev.ua
Web-site: www.srsrecords.com

