

MODULAR ARCHITECTURE

SYSTEM FLEXIBILITY AND
SCALABILITY

ROLE/GROUP BASED DATA
ACCESS CONTROL

CROSS-PLATFORM
APPLICATION

CUTTING-EDGE CODING
ALGORITHMS

DIGITAL AUDIO VIDEO
RECORDING

COLLECTIVE WORK WITH
DOCUMENTS

DOCUMENT HISTORY
TRACKING

INTEGRATION WITH CASE
MANAGEMENT SYSTEMS
THROUGH PROTECTED API

DISTRIBUTED STORAGE
SYSTEM

ONLINE STREAMING AND
NETWORK TECHNOLOGIES

Web technologies for audio and video recording and court reporting

Functionality

- Simultaneous digital multi-channel audio recording
- High resolution video recording
- Simultaneous work with documents by multiple users
- Centralized storage of audio/video recordings and minutes of proceedings
- Flexible role/group access control system
- Recording management, minutes/court report editing and audio-video recordings playback via the WEB interface from any workplace during a court proceeding or after its end
- Local and centralized management of recordings in courtrooms
- Creation of minutes of proceedings on the basis of unified templates
- Online web editor of minutes of proceedings
- Typing automation due to using tooltips and pop-up abbreviations
- Public and private note-taking on events in minutes of proceedings
- Incorporation of electronic documents to minutes of proceedings and import of third-party records
- Online chat on collaboration on documents
- Court proceedings scheduling
- Search for court proceedings by various parameters
- Saving of audio-video records and minutes to CD/DVD with division into several discs
- Simultaneous recording of copies of court proceeding to several discs
- High recording reliability

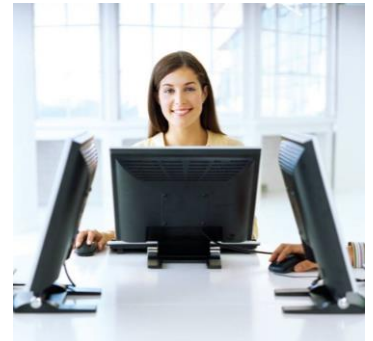

SRS True Records Architecture

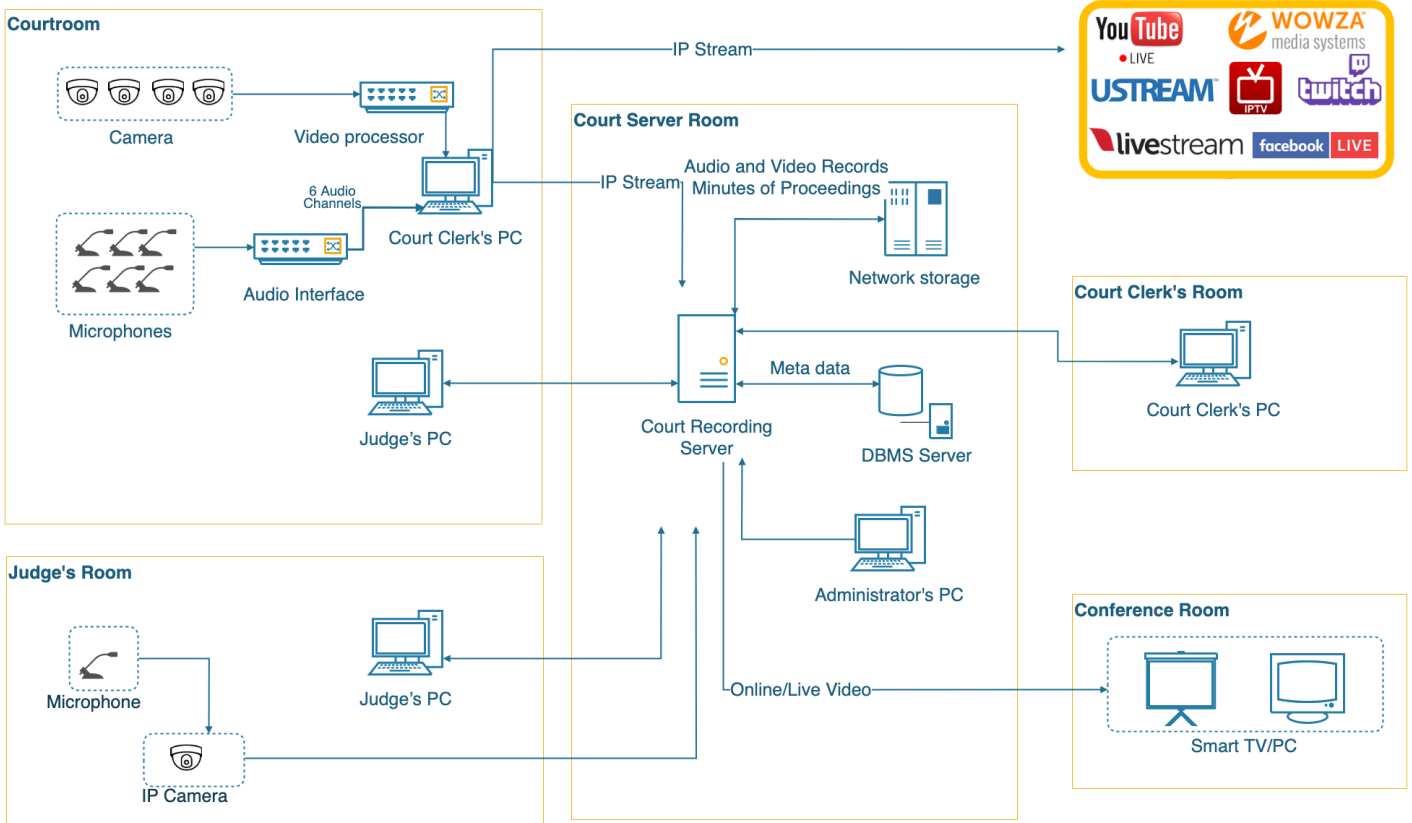

Each court participant has his/her assigned microphone in the courtroom. Digital cameras are focused on the court participants. Video signals from four video cameras are sent to the video processor, at the video processor output you can get a quad image, picture in picture, etc. The video signal with the combined image from the video processor output is transferred to the court clerk's PC for digitization, recording and broadcasting to therecording server. At the same time, the audio from the microphones of the court participants in the courtroomis transmitted to the audio interface via isolated channels and is transmitted via isolated channels to the courtclerk's PC, where it is also digitized, recorded and broadcast to the court recording server.

The court clerk manages the recording process and prepares the minutes of proceedings via the cross-browser application from her/his PC. Before the beginning of the court proceeding, the court clerk enters the appropriate metadata – details of the court proceeding. In case of integration with case management systems, this data is entered automatically.

The judge sees the minutes of proceedings, which the court clerk enters and can make his individual comments on the events of court proceeding from his computer through the SRS True Records cross-browser application. For online communication during the court proceeding, the judge and the court clerk can use the chat. Documents, photographs, video evidence demonstrated in electronic form during the court proceeding may be attached to the minutes of proceeding.

During the court proceeding, online video can be broadcast on the YouTube server, etc., as well as in the conference room and other courtrooms for viewing in real time by journalists, students, etc.

After the court proceeding, the court clerk can continue working with the minutes of proceedings from his/her workplace in the court clerk's room.

Several dozens of courtrooms can operate simultaneously with the court recording server. To store large volumes of data, a network storage is used, which actually stores audio-video records, minutes of proceedings, transcripts and other attached documents on the court case in electronic form. Each user has access to the data and functions of the system according to the assigned rights.



Special Recording Systems, LLC

Address: Solomyanska str, office 218, Kyiv, Ukraine, 03110
 Tel/fax: +380-44-248-7990(91)
 E-mail: info@srs.kiev.ua
 Web-site: www.srsrecords.com

